

CUSTOMER NAME:	
CUSTOMER REF NO:	
PROJECT NAME:	
PART NO:	
A.GH.1000.C	
DESCRIPTION:	
Above ground, 1000 litre capacity horizontal Grease arrestor. 1800 long by 1000 diameter tank with a 600 diameter manway with Screw top access Cover. This system comes equipped with a flow control system.	
SCALE: N.T.S	SIZE: A3
DRAWING NO.:	
SHEET: 1	
REV: 1	
Drawn By: NR	Date: 22/01
Checked By:	Date:
Approved By:	Date:

Dig Add
 CONFIDENTIAL - The drawings must not be disclosed to any third parties without written permission from Protec FRP. Unauthorised disclosure may result in prosecution.
 © Protec FRP - This drawing is the property of Protec FRP ACN: 609512905 and is subject to return on demand. It is submitted for the use only in connection with the proposal and contracts of Protec FRP with the expressed conditions that it is not to be reproduced or copied in any form. This data must only be used in accordance with our standard terms and conditions.
 © Copyright
 Protec FRP accepts no responsibility for any loss or damage resulting from any person acting on this information. The details and dimensions contained in this document may change, please check with Protec FRP for confirmation of current specifications.

APPROVED FOR CONSTRUCTION
 This drawing replaces all previous revisions
 Name: _____
 Client: _____
 Position: _____
 Signed: _____
 Date: _____

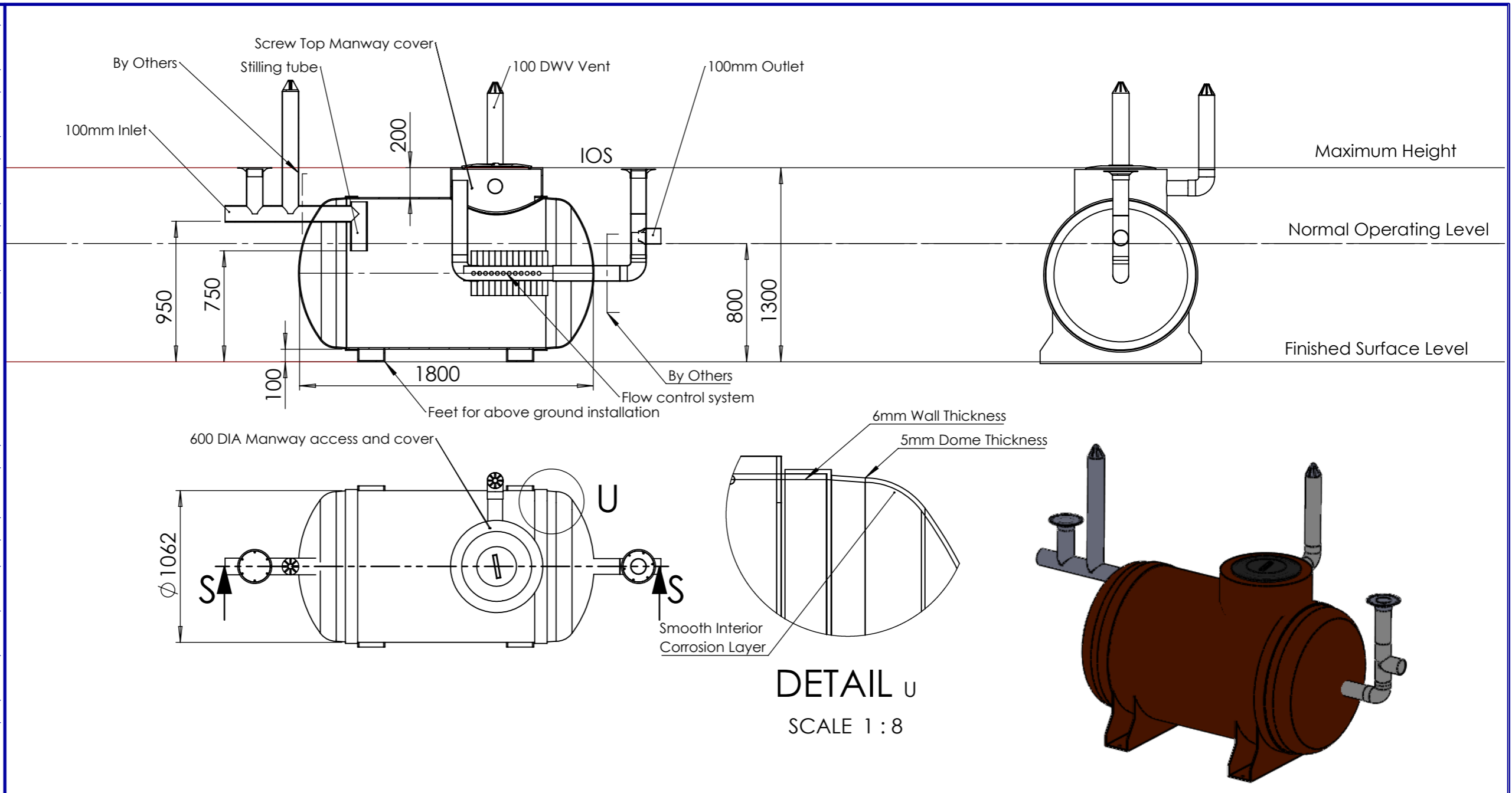

DETAIL U
 SCALE 1 : 8

GREASE ARRESTORS BY AUSTERE PUMPS

A grease arrestor by AUSTERE PUMPS is a system that is made from high strength and long life fibre reinforced polymers to intercept and remove almost all greases and solids before they enter the water systems. The processes used in grease arrestors is very simple in theory, and hence provide an simple an effective method of removing grease from sewerage. The grease is collected in these large systems where the grease layer is decomposed and broken down in an anaerobic process.

STANDARDS

1. AS 5200 - 2005 - Procedures for certification of plumbing and drainage products
2. AS 3500:2003 - Plumbing and Drainage
3. AS/NZ 4494:1998 - Discharge of commercial and industrial liquid waste to sewer - General performance requirements.

HORIZONTAL ABOVE GROUND INSTALLATION

Ensure that the surface that the tank will be installed on is smooth, flat, and designed to support the weight of the tank. The Pad design is the responsibility of an engineer and construction team organised by the contractor. All specifications of the tank are to be supplied by AUSTERE PUMPS at request. The support surface of the tank can be made from concrete pad or apron, stone or gravel crushing's.

The GA is to be supported on a minimum of a 100 mm thick concrete pad or on 98% compacted level ground with 20 mm sand base. The GA does not require a stand. All pipes connecting to the GA shall be fully supported; there should be no stress on the tank connections. All storm water must be diverted away from GA to prevent undermining of supports or foundations. Vertical clearance above unit at site must be at least 1.2 metres.

Buffer Pads, Anchoring systems and Protection barriers may need to be installed, all of which need to be completed to the specifications of a certified Engineer. Install all exterior connections must be connections and ensured no interference with exterior objects